

3-78 Oil

# ORIGINAL INSTRUCTION MANUAL

GREENLINE

READ THIS INSTRUCTION MANUAL BEFORE USING THIS APPLIANCE

SERIAL No: .....  
(To be completed by user)



## MODEL DESCRIPTION

Greenline BVC GS 3-78 Oil 230V

## PART NUMBER

28 50151 22

# TABLE OF CONTENTS

<b>Overview</b> <i>Safety, usage, guidelines &amp; important notes</i>	<b>02</b>
<b>Parts Description</b> <i>Vacuum Cleaner Parts List &amp; Diagram</i>	<b>03</b>
<b>Usage</b> <i>Step by Step.</i>	<b>04</b>
<b>Maintenance</b> <i>Step by Step.</i>	<b>05</b>
<b>Safety</b> <i>Safety rules, Performance Details</i>	<b>06</b>
<b>Labels</b> <i>Safety and warning machine labels</i>	<b>07</b>
<b>Spares</b> <i>Vacuum cleaner spares and part numbers.</i>	<b>08</b>
<b>Technical Data</b> <i>Technical Data, Noise and Vibrations..</i>	<b>09</b>

**GREENLINE**  
BVC 3-78 Oil



# VACUUM CLEANER USER MANUAL

This user-friendly guide is here to help you understand the essential functions and ensure a safe and effective cleaning experience.

## OVERVIEW

The vacuum cleaner is designed for both dust and liquid pick-up, featuring a sturdy build, powerful performance, and efficient tools for thorough cleaning. It is suitable for collective use in various settings such as hotels, schools, factories, and shops.

## SAFETY & USAGE

Carefully read the manual before use for a safe environment.

Assemble the device correctly before use, ensuring filter elements are in place and efficient.

Keep the appliance away from children, individuals with reduced abilities, or those lacking experience.

Children should not use the appliance as a toy, and users must be properly trained

## GUIDELINES

If you encounter any issues, always consult your dealer for assistance.

Buyers must ensure informed individuals use the vacuum, and any modifications may void the warranty.

## IMPORTANT NOTES

In case of a lost or damaged manual, contact the manufacturing company for a replacement.

If you sell the vacuum, provide the new owner with this manual or inform them about the manufacturing company's contact details.

# PARTS DESCRIPTION

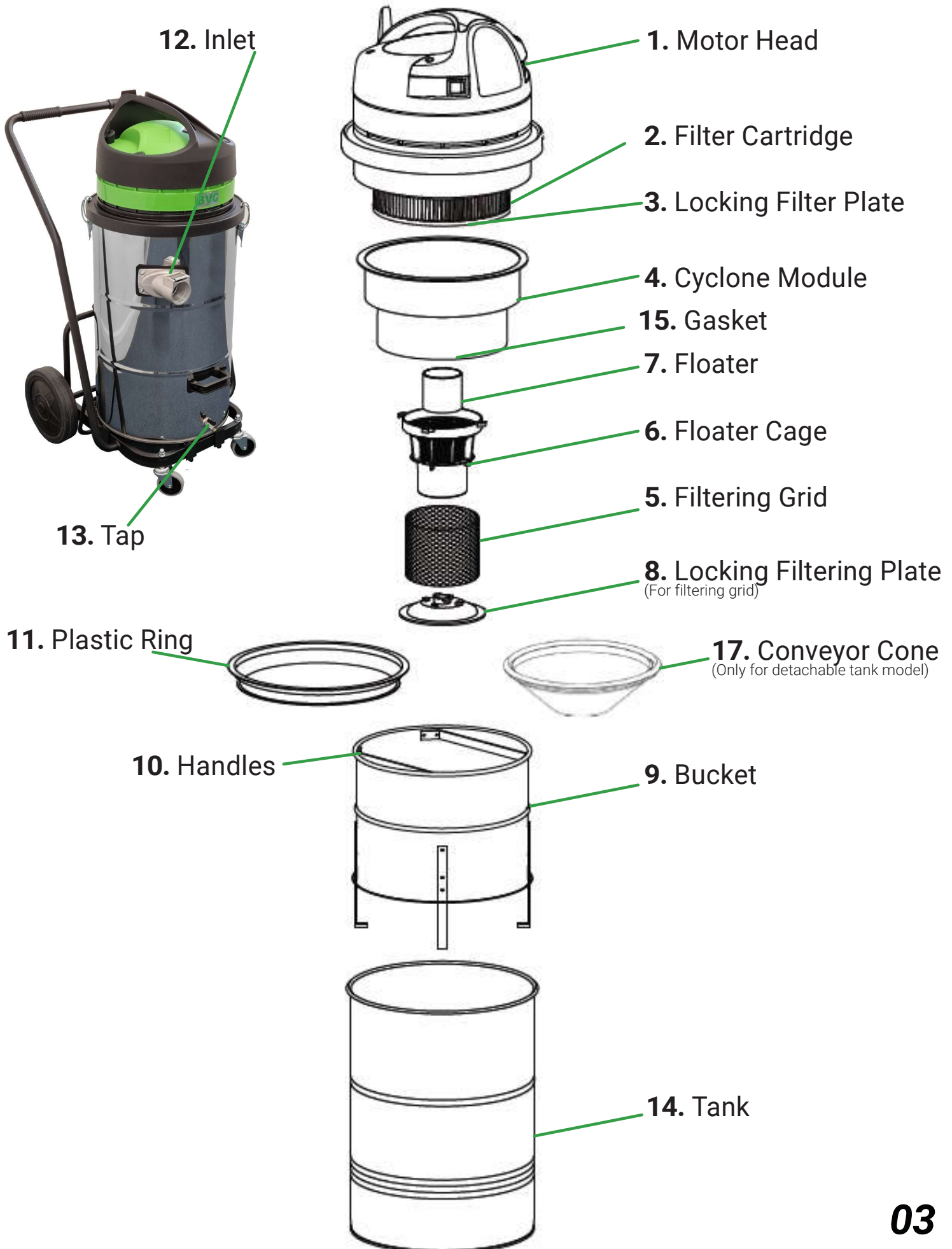

# USAGE

## BEFORE STARTING:

- 1** Check that all the parts and the filtering elements are in place and correctly assembled.
- 2** Check that the tap 13 is shut.
- 3** Check that the floater 7 is intact and free to move inside the float cage 6.
- 4** Check that the plastic ring 11 is correctly placed.

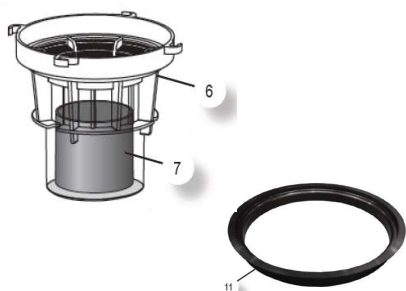

## EMPTYING THE TANK

- 1** Turn off the appliance
- 2** Empty the tank through the tap 13
- 3** For tilting tank version 16, unlock the hooks, lift tank head 1, and remove the plastic ring 11
- 4** For detachable tank version 19. Raise the lever, remove the tank head 1, and remove the conveyor cone 17
- 5** For all versions remove the bucket 9, empty it and remove the scraps and debris. If necessary, tip over the tank in order to completely empty the tank 16 19
- 6** Check that the filtering grid 5 is free from scraps
- 7** Check that the floater 7 is free of debris that can block the floater motion to move inside of the floater cage 6
- 8** Check also that the flexible hose is unclogged

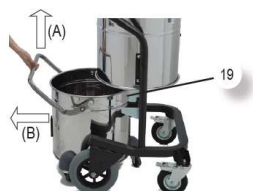

## VACUUM USE:

- 1** Check that the power cord of the vacuum cleaner is not damaged
- 2** Check the efficiency of all electrical controls present on the vacuum cleaner
- 3** Check that the filtering unit is not damaged
- 4** Check the filling level of the container tank
- 5** Check that the suction hose and other accessories are not damaged
- 6** Check the seal of the gasket when you close the hooks of the motor head
- 7** If the vacuum cleaner is moved, check that the line voltage corresponds with the voltage reported on the label of the vacuum cleaner
- 8** Check the position of the plastic ring 11, this must be placed between the tank and the bucket 9.

## SUGGESTED AFTER 100/200 HOURS WORK:

- 1** Check the seal of the gaskets of the motor head and the tank
- 2** Check if the edge of the container tank has been damaged by any improper use
- 3** Check the conditions of all filters (cartridge, filter grid, floater cage) they must not have holes or cuts. In this case you must replace them
- 4** Check the conditions of the label reporting all the technical data. If it should be illegible, please contact the manufacture company
- 5** Check the conditions of the wheels



# MAINTENANCE

## WARNING

If the suction is reduced, maybe the floater is blocking the airflow, to avoid that the liquid reaches the motor head. Turn off the vacuum cleaner and check the liquid level inside the tank. If the level is low, check if the filtering cartridge is not clogged and the suction hose is free from scraps or debris.

## FLOATER CONTROLS

- 1 Unlock the hooks and lift the head 1
- 2 Unfasten the plate knob B and remove the filter grid 5
- 3 Turn the filter cage 6 counterclockwise to unhook it from the cyclone module 4
- 4 Remove the floater 7 and verify that is whole and free to move inside of the floater cage



## REPLACING THE FILTER CARTRIDGE



- 1 Unlock the hooks and lift the motor head 1

- 2 Unfasten the plate knob A

- 3 Remove the old filter



- 4 Place the new filter cartridge and align it with the guide placed on motor head

- 5 Place the locking filter head

- 6 Lock the locking filter plate through the knob A

## HOSE

It is possible for the hose to decrease in suction power. This can happen for different reasons, for example: the nature of the material sucked up and particularly hard working conditions. We suggest to periodically check that the hose does not show any dirt inside it and that it is not damaged outside.



## SEALS

It is possible for the sealing gaskets to lose their functionality, due to time and hard conditions of work. This results in a decreased suction power. We suggest to periodically check all the hooks and gaskets of:

- 1 Tank sealing

- 2 Sealing of the tangential inlet 12

- 3 Sealing of the tank tap 13

- 4 Sealing of the floater 7, it must be free from scraps or debris and must be free to move

- 5 Sealing of gasket 15, placed at the centre of cyclone module

- 6 Sealing of the gasket of the head



The suction inlet 12 is tangential, in order to allow the dust to lay down at the bottom of the tank.

The flexible hose must always be kept unrolled in order to allow the scrap to easily run inside it and reach the tank. Any slowing due to bends or narrowing causes the obstruction of the hose itself. If it's blocked, shake it with waving movements.

# SAFETY

Ensure safe and proper use of this device by following these essential guidelines

## 1. Safety Precautions:

Follow local standards for packaging disposal.

Ensure the voltage matches, and the power cable is unrolled before use.

Avoid handling the plug or appliance with wet hands.

Refrain from picking up items that can damage filter elements.

Never immerse the machine in water or use a pressure jet for cleaning.

Use below 2000 m above sea level

## 2. Usage Warnings:

Avoid picking up dangerous dust or flammable, incandescent, explosive, or toxic dust/blends.

Machine should not be left unsupervised while working; unplug when not in use.

Use on a safe, non-sloping plane for assembly, movement, and storage.

Keep body parts away from openings.

Only use original spare parts; no tampering or modification allowed.

## 3. Maintenance Guidelines:

Disconnect power before maintenance.

Regularly inspect gaskets, seals, plastic parts, filters, and switches for damage.

Replace damaged parts promptly.

Only authorized service centers should handle repairs and maintenance.

Clean polyester filter after each use and replace filter bag when full.

Clean all parts with a damp cloth after each use.

## 4. Electrical Cord Safety:

Inspect power cord for damage; replace if necessary.

Authorized service center for power cord replacement.

Use appropriate extension cables; keep dry and avoid conductive surfaces.

## 5. Supervision and Usage:

Don't allow unsupervised use by children.

Only authorized service centers should perform repairs or maintenance.

## 6. Liquid Handling:

Switch off the appliance in case of foam or liquid leak.

Upright the appliance before switching off motors in case of overturning.

Additional socket for dry mode only; using it otherwise can lead to fires and dangers.

## 7. Post-Operation Safety:

Avoid picking up water from sinks or tubs.

Do not use as a pump for cleaning drains or plumbing fixtures.

Do not use aggressive soaps as they can damage the appliance.

Do not use outdoors or in a cold environment.



# LABELS



CE

THE CE MARK “EUROPEAN COMPLIANCE” MEANS THAT THE PRODUCT IS IN ACCORDANCE WITH THE ESSENTIAL REQUIREMENTS PROVIDED BY THE LAW, CONCERNING SAFETY AND PUBLIC HEALTH MEASURES, PROTECTION OF THE CONSUMER, ETC.



WARNING: THESE SYMBOLS WILL BE USED TO REMIND THE OPERATOR TO PAY ATTENTION TO OPERATIONS THAT MAY CAUSE LESIONS, INCLUDING DEATH, TO THE OPERATOR OR TO OTHER PEOPLE OR ANIMALS NEARBY. FURTHERMORE, THE OPERATIONS INDICATED BY THESE SYMBOLS MAY CAUSE DAMAGES, EVEN IRREPARABLE ONES, TO THE SUCTION DEVICE.

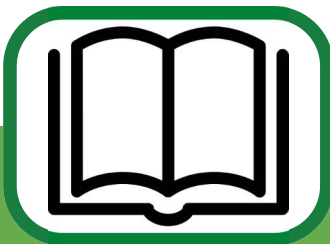

ATTENTION: PLEASE READ CAREFULLY THE INSTRUCTION MANUAL BEFORE USING IT. IT IS RECOMMENDED TO KEEP THIS MANUAL FOR FUTURE REFERENCES.



DO NOT DISPOSE OF POWER TOOLS INTO HOUSEHOLD WASTE! ACCORDING TO THE EUROPEAN DIRECTIVE 2012/19/EU ON WASTE ELECTRICAL AND ELECTRONIC EQUIPMENT (WEEE) AND ITS INCORPORATION INTO NATIONAL LAW, POWER TOOLS THAT ARE NO LONGER SUITABLE FOR USE MUST BE SEPARATELY COLLECTED AND SENT FOR RECOVERY IN AN ENVIRONMENTAL-FRIENDLY MANNER.



## STANDARD EQUIPMENT

CODE: FTDP00285

WASHABLE POLYESTER  
CARTRIDGE 2.960cm<sup>2</sup>



CODE: FTDP28755

MESH FILTER



CODE: SECC00116

BUCKET SIEVE 30L



## OPTIONAL ACCESSORIES

### ANTI-OIL TOOL KIT (FOR INLET 38mm) - 280000928

CODE: TBFX00945

ANTI-OIL FLEXIBLE HOSE  
38mm WITH CUFFS 4m



CODE: LAFN28240

DOUBLE STEEL WAND 38mm



CODE: SPPV01217

BRUSH 28mm WITH INTER-  
CHANGEABLE SLIDES



CODE: SPPV72080

CHROMED FLAT LANCE 38mm



### ANTI-OIL TOOL KIT (50mm) - 280000447

CODE: TBFX00480

ANTI-OIL FLEXIBLE HOSE  
50mm WITH CUFFS 3m



CODE: LAFN49581

COMPLETE ALUMINIUM  
DOUBLE WAND 50mm



CODE: SPPV49592

WET FLOOR TOOL 50mm



CODE: SPPV01654 (FOR 1 PC)

BRISTLE SLIDES  
(KIT COMES WITH 2PCS)



CODE: SPPV49594

RUBBER BRUSH 50mm



# TECHNICAL DATA

USAGE	WET & DRY
NUMBER OF PHASES	SINGLE PHASE
VOLTAGE / FREQUENCY	220-240/50-60
N. AND TYPE OF MOTOR	3 x 2 STAGES
POWER	3000 - 3600 MAX
WATER LIFT	2470
AIRFLOW	630
TANK CAPACITY	78
DIAMETER OF INLET	60
FILTERING SURFACE	2960
SOUND PRESSURE LEVEL	76
DIMENSIONS (LxWxH)	550 x 600 x 980
WEIGHT	28

## NOISE

Values measured according to EN60704-1 (1997) / EN 60704-2-1 (2001) ISO 3744 standards

Motors	LpA [dB]	KpA [dB]	LwA [dB]	KwA [dB]
1	70 ÷ 76	2.5	-	-
2	74 ÷ 80	2.5	-	-
3*	78 ÷ 84	2.5	92 ÷ 98	2.5

\*Wear hearing protection

## VIBRATIONS

Hand-arm vibrations on the suction hose are less than 2,5 m/s<sup>2</sup> as recommended by ISO 5349-1

Under adverse network conditions, the appliance may cause temporary drops in voltage.

## IMPORTANT INFORMATION ABOUT OPTIONAL VERSIONS:

### Appliance with floor head additional socket (optional)

The socket -U- it is designed to connect a floor head.

### **WARNING: Maximum power allowed is 200W.**

Don't connect electrical floor brushes with a bigger load. This may result in a fire hazard or electric shock.



**IP CLEANING S.r.l.**  
Sede Legale - Registered Office  
Viale Treviso n°63 fraz. Summaga  
30026 Portogruaro (VE) ITALY

Sede produttiva - Production premises  
Via E. Fermi, 2  
26022 Castelverde (CR) ITALY

I	DICHIARAZIONE CE DI CONFORMITÀ	E	DECLARACIÓN CE DE CONFORMIDAD
GB	CE CONFORMITY DECLARATION	NL	KONFORMITEITSVERKLARING CE
F	DECLARATION DE CONFORMITE CE	N	BEKREFTELSE OM OVERENSSTEMMELSE CE
D	CE KONFORMITÄTSEKHLARUNG	P	DECLARAÇÃO CE DE CONFORMIDADE

2006/42/CE (Machinery Directive)  
2014/30/UE (Electromagnetic compatibility EMC)  
2011/65/UE (Directive ROHS)

I - DICHIARIAMO SOTTO LA NOSTRA ESCLUSIVA RESPONSABILITÀ CHE IL PRODOTTO AL QUALE QUESTA DICHIARAZIONE SI RIFERISCE È CONFORME ALLE SEGUENTI NORME O AD ALTRI DOCUMENTI NORMATIVI.

E - BAJO NUESTRA EXCLUSIVA RESPONSABILIDAD, DECLARAMOS QUE EL PRODUCTO, AL QUE ESTA DECLARACION SE REFIERE, ES CONFORME CON LAS SIGUIENTES NORMAS U OTROS DOCUMENTOS NORMATIVOS.

GB - WE DECLARE ON OUR OWN RESPONSIBILITY THAT THE PRODUCT TO WHICH THIS DECLARATION REFERS IS IN ACCORDANCE WITH THE FOLLOWING RULES OR WITH OTHER DOCUMENTS CONTAINING OFFICIAL RULES.

NL - WIJ VERKLAREN ONDER ONZE EXCLUSIEVE VERANTWOORDELIJKHEID DAT HET PRODUCT, WAAROP DEZE VRKLARING BETREKKING HEEFT, KONFORM IS AAN DE VOLGENDE NORMEN EN AAN ANDERE DAARVAN DEEL UITMAKENDE DOCUMENTEN.

F - NOUS DECLARONS SOUS NOTRE EXCLUSIVE RESPONSABILITE QUE LE PRODUIT AUQUEL CETTE DECLARATION SE REFERE EST CONFORME AUX NORMES SUIVANTES OU A D'AUTRES DOCUMENTS QUI CONTIENNENT NORMES OFFICIELLES.

N - VI FORSIKRER UNDER EGET ANSVAR AT FOLGENDE PRODUKT SOM OMFATTES AV DENNE BEKREFTELSEN ER I OVERENSSTEMMELSE MED VILKARENE I FOLGENDE DIREKTIV ELLER ANDRE LOVER.

D - AUF UNSERER ALLEINVERANTWORTUNG ERKLÄREN WIR, DASS DAS PRODUKT, WORAUF SICH DIESE ZUSTIMMUNGEN BEZIEHT, FOLGENDEN NORMEN ODER ANDEREN VORSCHRIFTEN GEMÄSS IST.

P - DECLARAMOS SOB A NOSSA EXCLUSIVA RESPONSABILIDADE QUE O PRODUTO AO QUAL ESTA DECLARAÇÃO SE REFERE ESTA EM CONFORMIDADE COM AS SEGUINTEs NORMAS OU OUTROS DOCUMENTOS NORMATIVOS.

IEC 60335 - 1:2010 + A1:2013 + A2:2016 - EN 60335 - 1:2012 + AC:2014 + A11:2014+ A13:2017  
IEC 60335 - 2 - 69:2016 - EN 60335 - 2 - 69:2012 - EN 62233:2008  
CISPR 14-1:2016 - EN 55014-1:2017  
CISPR 14-2:2015 - EN 55014-2:2015  
IEC 61000-3-2:2018 - EN 61000-3-2:2019  
IEC 61000-3-3:2013 + A1:2017 - EN 61000-3-3:2013

Person authorised to compile the technical file  
Persona autorizzata a compilare il fascicolo tecnico  
IP Cleaning S.r.l.  
Via E. Fermi, 2 26022 Castelverde (Cremona) - ITALY

Legal Representative  
Rappresentante legale  
dott. Pietro Annibaldi Corsano

Castelverde, 01/06/2021