

01 65830 00

TI60DCFA - ATEX

ORIGINAL INSTRUCTION MANUAL

FOR VACUUM CLEANER

READ THIS INSTRUCTION MANUAL BEFORE USING THIS APPLIANCE

SERIAL No:

(To be completed by user)



The model above carries this ATEX Certification Code

ATEX Certification Code
UK CE Ex II 3 D Ex tc IIIC T135°C Dc

MODEL DESCRIPTION

TI60DCFA 4.0kW 400v 3ph ATEX D22

TI60DCFA 2.2kW 400v 3ph ATEX D22

PART NUMBERS

55 64315 00

55 64334 00

TABLE OF CONTENTS

TI60DCFA – ATEX VACUUM CLEANER

UNIT DESCRIPTION.....	3
IMPORTANT USER INFORMATION.....	4
RISK ASSESSMENT (ATEX).....	5
WARNINGS.....	6
SPECIAL CONDITIONS FOR SAFE USE.....	7
NORMAL USE.....	8
ELECTRICAL SUPPLY.....	9
ATEX EQUIPMENT LIST.....	10
SPARES.....	14
WET COLLECTION.....	15
MAINTENANCE.....	16
BELT MAINTERNACE.....	17
FILTER MAINTENANCE.....	18
GENERAL CARE.....	19
DECLARATION OF CONFORMITY.....	20

UNIT DESCRIPTION

This appliance is a heavy-duty industrial dry pick-up Vacuum Cleaner consisting of:

A multistage centrifugal exhauster to create the vacuum and airflow driven by a three phase induction motor which in turn is controlled by its own starter.

A filter separator made up of a multiplicity of fabric filter sleeves with a manual shaker to enable filter cleaning.

A collection bin, which, by means of a manual lifting mechanism be raised into the collection position or lowered to the ground for removal and emptying.

A HEPA filter which is fitted between the centrifugal exhauster and the clean side of the filter separator to provide a secondary level of protection to prevent ingress of product into the centrifugal exhauster.

All of the above is mounted on a wheeled frame, to enable the appliance to be manually moved.

A selection of accessories (some optional) consisting of a collection hopper (to increase the collection volume) hoses, extension arms and collection tools etc are available.

IMPORTANT USER INFORMATION

TI60DCFA

This appliance is a Dry Pick Up Vacuum Cleaner for collecting duct. Collection is directly into the Drum assembly. It is designed to be used by an operator within four different environments.

The ATEX certification code which is shown on the machines rating plate is made up as follows:

BVC	QUIREPACE LTD. PO16 8XU, UK	Sales / Service +44 (0)23 9260 3700
Year of Manufacture	20	UK CA CE www.bvc.co.uk
Model No.	TI kW	400/3/50 ATEX
Serial No.		C
Ex II 3 D Ex tc IIIC T135°C Dc Do not open the Motor or Starter when an Explosive Atmosphere is present		

ONE

To pick up inert dust and debris in an atmosphere where inflammable dust, gases or vapours are never present.

TWO

To pick up inert dust and debris in a Dust Zone 22, where the dust in the potentially explosive atmosphere may be conductive.

THREE

To pick up inert dust and debris that may ignite or explode in a Dust Zone 22, where the dust in the potentially explosive atmosphere may be conductive.

FOUR

To pick up conductive dust or debris that may ignite or explode in a Dust Zone 22, where the dust in the potentially explosive atmosphere may be conductive.



The **UKCA** mark (UK Conformity Assessed).



The **CE** mark (European Conformity Assessed).



The distinctive community mark showing a product is suitable for use in an explosive dust atmosphere.

II Equipment group II (surface industries)

3 Category 3 product

D Explosive dust atmosphere

Ex Explosion protection (letters below indicate type of protection)

tc Protection concept (Enclosure ingress protection level - IP6X with IIIC)

IIIC Equipment group - Combustible dusts, Conductive Dusts

T135°C Surface temperature for dust evaluation is less than 135°C

Dc Equipment protection level (Dust zone 22)

RISK ASSESSMENT (ATEX)

RESPONSIBILITY

The risk assessment will be the responsibility of the customer/end user and should take into account (but not limited to) the characteristics of the material being collected.

If this vacuum cleaner is used for collecting flammable/explosive material or within a zoned area, classified under the ATEX Directive 2014-34 EU, then a risk assessment must be carried out by a competent person to verify the suitability of the application.

MATERIAL CHARACTERISTICS

- Q Spark ignition sensitivity
- Q Hot surface ignition sensitivity (cloud)
- Q Hot surface ignition sensitivity (layer)
- Q Explosion severity
- Q Flammable gas generation
- Q Burning behaviour
- Q Thermal instability
- Q Chemical instability
- Q Static electricity generation
- Q Impact of collected material
- Q The ATEX certification code for the appliance being assessed. (See the rating plate on the machine).

PREPARATION FOR USE



- Q Unpack and identify each item of equipment against packing note.
- Q Check that the details given on the motor rating plate are in accordance with your electricity supply
- Q Check the rating plate against the ATEX zone, in which the machine and any accessories are to be used.



Warnings

- 1** This appliance must only be operated by suitably trained and authorised personnel
- 2** Only use accessories approved by the manufacturer.
- 3** This appliance or the accessories must not be modified.
- 4** This appliance must not be stored or used in wet conditions i.e. outside in the rain
- 5** The filtration systems on this appliance must only be configured as shown in these instructions.
- 6** When collecting dust or debris that may ignite or explode, empty the cleaner after every use.
- 7** The earth path continuity between the pick-up nozzle and the electrical earth of the fixed electrical supply should be checked (Should be $<800\text{M}\Omega$) by a competent person at regular intervals and documented records be kept of these checks.
- 8** This machine must not be installed as a fixed extraction system and/or run unattended.
- 9** Do not pull the machine along by the flexible cord.
- 10** This appliance must only be repaired by SUITABLY TRAINED and authorised personnel and only genuine BVC spare parts be used.
- 11** Ensure that the product being collected is suitable for vacuum cleaning.
- 12** Noise emission 80 dB(A) @ 1m
- 13** Weight (EMPTY) = 153 Kg

SPECIAL CONDITIONS FOR SAFE USE

- 1** The equipment must be inspected and maintained in accordance with the manufacturer's recommended schedule.
- 2** The user shall regularly inspect the equipment and cable and return to the manufacturer if there are signs of deterioration or damage.
- 3** The equipment shall be cleaned in accordance with the manufacturers recommended schedule.
- 4** The deflector plates shall be inspected for signs of deposited rust and deformation in accordance with the manufacturers recommended schedule.
- 5** The equipment must be wired to the electrical supply in accordance with the manufacturers instructions.
- 6** Earth continuity between the hose end and the equipment earthing point shall be checked at regular intervals in accordance with the manufacturer's instructions.
- 7** Equipment shall not be used where aggressive substances may be present.
- 8** Do not open the motor terminal box when an explosive atmosphere is present.
- 9** Do not open the starter when an explosive atmosphere is present.
- 10** Replace silicone grease on joints on motor after every opening. Ensure that silicone grease is compatible with the environment the appliance is used within.
- 11** Replacement screws used on the motor must be 8.8 to EN 20898.
- 12** Parts of the equipment are manufactured from plastic material with anti static properties. Care should be taken to avoid the use of the equipment where substances, which may degrade plastics, are present.



NORMAL USE

STARTING

1. Check the deflector plate(s) for signs of deposited rust or deformation, which should be rectified prior to use.
2. Ensure all hoses and collection hoppers are connected.
3. Operate the start button.

DURING USE

1. Take care to keep clear of the hose end and the material being collected at the intake.
2. Do not attempt to lower or raise the collection drum with the vacuum unit running.
3. Do not attempt to open or close the lid on the collection hopper (if used) with the vacuum unit running.
4. The machine should be stopped if abnormal noise or vibrations are observed.

STOPPING

- 
1. Ensure the collection hose(s) are free from any product.
 2. Press the stop button.

EMPTYING THE BIN

1. Release the latch and gently lower the collection bin to the ground
2. Empty the collection bin using the optional lifting frame if required.
3. Replace the bin by holding the handle in the raised position and push the collection bin under the machine so that the hooks on the bin engage on the lifting pins.
4. Lift the bin using the handle and hold in place by engaging the latch.

ELECTRICAL SUPPLY



WARNING – THIS APPLIANCE MUST BE EARTHED



The electrical connections of these machines must be carried out by a competent electrician.



As this machine is an earthed appliance it must be fitted with a cable having an earth core and therefore must be connected to an earthed supply.

The machine is fitted with a 4 core cable, 3 cores (one for each phase) and 1 core for earth

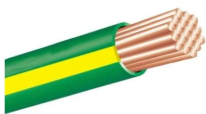
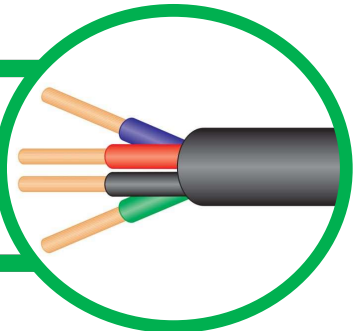







Green/Yellow for 'E' earth lead.

When wired to the mains plug, but before use, the rotation of the exhauster must be checked. Switch on momentarily and check that rotation is anticlockwise looking through the window. If the direction of rotation is incorrect, interchange any two of the phase connections at the free end of the cable.



ATEX EQUIPMENT LIST

ATEX 38mm EQUIPMENT SS = STAINLESS STEEL AS = ANTISTATIC

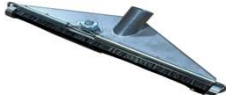
DESCRIPTION	ILLUSTRATIONS NOT TO SCALE	PART NUMBER	MATERIALS OF CONSTRUCTION
ATEX HOSE 38 SD M/M PE BK AS 7.5M		54 64150 02	ANTI STATIC POLYETHYLENE HOSE STAINLESS STEEL 304 COUPLING.
ATEX HOSE 38 SD M/M PE BK AS 3.75M		54 64150 01	ANTI STATIC POLYETHYLENE HOSE STAINLESS STEEL 304 COUPLING.
ATEX 38 EXTENSION ARM SS X 470		29 03803 00	STAINLESS STEEL 304.
ATEX 38 BEND 30° SS		29 03802 00	STAINLESS STEEL 304.
ATEX 38 CREVICE TOOL SS X 445		29 03807 00	STAINLESS STEEL 304.
ATEX 38 DUSTING BRUSH A/S 100 DIA		29 03806 10	CONDUCTIVE POLYETHYLENE BODY CONDUCTIVE BRISTLE WITH BRASS WIRE.
ATEX 38 CREVICE TOOL AS 300		29 03808 10	CONDUCTIVE POLYPROPYLENE.
ATEX 38 FLOOR BRUSH AS X 375 HD		29 03817 00	CONDUCTIVE POLYPROPYLENE BODY CONDUCTIVE BRISTLE WITH BRASS WIRE.
ATEX 38 FLOOR TOOL X 410 DRY SS		55 64130 03	STAINLESS STEEL BODY & WHEELS 316. ANTI STATIC NYLON BRUSH MILD STEEL. ZINC PLATED BRUSH RETAINERS AND WHEEL CARRIER.
ATEX 38 FLOOR TOOL X 410 WET SS		55 64130 04	STAINLESS STEEL BODY & WHEELS 316. ANTI STATIC RUBBER STRIP MILD STEEL. ZINC PLATED BRUSH ETAINERS AND WHEEL CARRIER.





ATEX EQUIPMENT LIST

ATEX 51mm EQUIPMENT SS = STAINLESS STEEL AS = ANTISTATIC

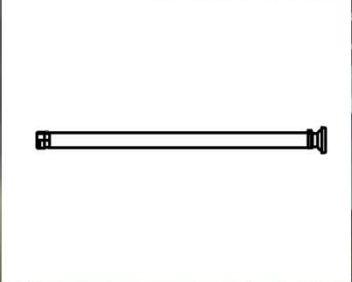
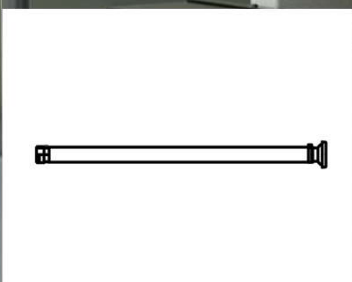
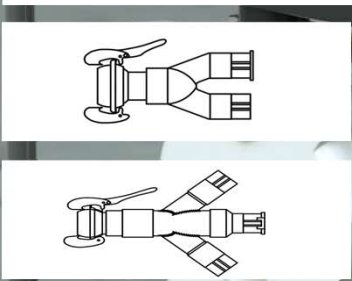
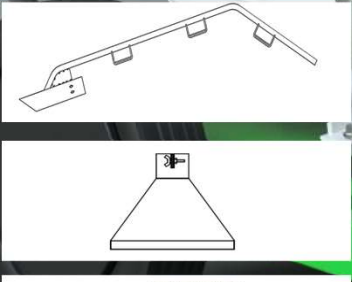
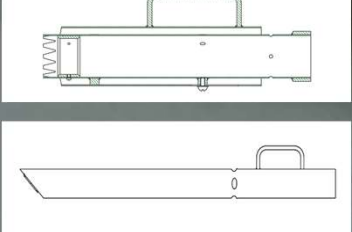

DESCRIPTION	ILLUSTRATIONS NOT TO SCALE	PART NUMBER	MATERIALS OF CONSTRUCTION
ATEX HOSE 51 SD M/M PE BK AS 7.5M		54 64160 02	ANTI STATIC POLYETHYLENE HOSE STAINLESS STEEL 304 COUPLING.
ATEX HOSE 51 SD M/M PE BK AS 3.75M		54 64160 01	ANTI STATIC POLYETHYLENE HOSE STAINLESS STEEL 304 COUPLING.
ATEX 51 EXTENSION ARM SS X 900		53 63368 00	STAINLESS STEEL 304.
ATEX 51 BENT 50° EXTENSION SS		53 63367 00	STAINLESS STEEL 304.
ATEX 51 BEND 50° SS		53 63366 00	STAINLESS STEEL 304.
ATEX 51 FEMALE TO 38 MALE TOOL SS		53 62647 02	STAINLESS STEEL 304.
ATEX 51 CREVICE TOOL SS		53 63340 01	STAINLESS STEEL 304.
ATEX 51 DUSTING BRUSH A/S 125 DIA		55 52666 07	ANTI STATIC RUBBER BODY ANTI STATIC NYLON BRUSH.
ATEX 51 BENCH TOOL RUBBER X 500		53 63324 00	NEOPRENE RUBBER WITH ANTISTATIC PROPERTIES.
ATEX 51 FLOOR TOOL X 410 DRY SS		55 64130 01	STAINLESS STEEL BODY & WHEELS 316. ANTI STATIC NYLON BRUSH MILD STEEL. ZINC PLATED BRUSH RETAINERS AND WHEEL CARRIER.
ATEX 51 FLOOR TOOL X 410 WET SS		55 64130 02	STAINLESS STEEL BODY & WHEELS 316. ANTI STATIC RUBBER STRIP MILD STEEL. ZINC PLATED BRUSH RETAINERS AND WHEEL CARRIER.

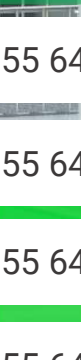
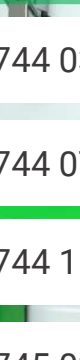
ATEX EQUIPMENT LIST

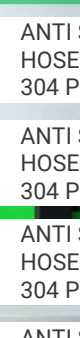
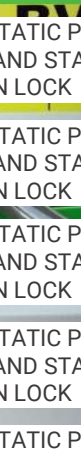
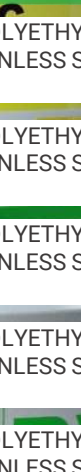
ATEX 76mm EQUIPMENT SS = STAINLESS STEEL AS = ANTISTATIC

DESCRIPTION	ILLUSTRATIONS NOT TO SCALE	PART NUMBER	MATERIALS OF CONSTRUCTION
ATEX HOSE 76 SD PL/FLL AS 3.75M		55 64744 03	ANTI STATIC POLYETHYLENE HOSE AND STAINLESS STEEL 304 PIN LOCK
ATEX HOSE 76 SD PL/FLL AS 7.5M		55 64744 07	ANTI STATIC POLYETHYLENE HOSE AND STAINLESS STEEL 304 PIN LOCK
ATEX HOSE 76 SD PL/FLL AS 15M		55 64744 15	ANTI STATIC POLYETHYLENE HOSE AND STAINLESS STEEL 304 PIN LOCK
ATEX HOSE 76 SD PL/PE AS 3.75M		55 64745 03	ANTI STATIC POLYETHYLENE HOSE AND STAINLESS STEEL 304 PIN LOCK
ATEX HOSE 76 SD PL/PE AS 7.5M		55 64745 07	ANTI STATIC POLYETHYLENE HOSE AND STAINLESS STEEL 304 PIN LOCK
ATEX HOSE 76 SD PL/PE AS 15M		55 64745 15	ANTI STATIC POLYETHYLENE HOSE AND STAINLESS STEEL 304 PIN LOCK
89Y LL MALE TO 2 X 51 FEMALE		55 63685 02	ALUMINIUM LM25 BODY WITH CHROME PLATED MAZAK HOSE CONNECTION POINTS AND STAINLESS STEEL LEVER LOCK.
89Y LL MALE TO 3 X 51 FEMALE		54 64343 00	STAINLESS STEEL 304 FABRICATION WITH CHROME PLATED HOSE CONNECTION POINTS AND STAINLESS STEEL LEVER LOCK
76 DIA TOOL WITH HOSE SUPPORT		53 63443 02	STAINLESS STEEL 304
76 GULPER TOOL ATTACHMENT (fits on 53 63443 02)		53 63666 02	STAINLESS STEEL 304
76 DIA BULK TOOL SERRATED END		65 27715 04	STAINLESS STEEL 304
76 DIA TOOL WITH MESH		53 63667 02	STAINLESS STEEL 304

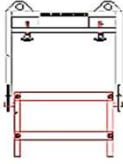
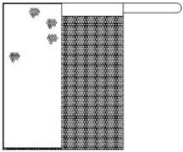
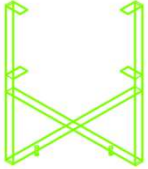
ATEX EQUIPMENT LIST

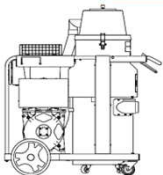
DESCRIPTION	ILLUSTRATIONS NOT TO SCALE	PART NUMBER	MATERIALS OF CONSTRUCTION
<p>DRUM LIFTING/TIPPING EQUIPMENT</p> <p>see separate instruction leaflet supplied with this accessory</p>		55 63068 00	MILD STEEL POLYESTER POWDER COATED
SWARF BASKET		54 63401 00	MILD STEEL ZINC PLATED
SWARF BASKET STAND		53 63354 00	MILD STEEL ZINC PLATED
FLOAT VALVE		54 63399 00	MILD STEEL ZINC PLATED PLASTIC FLOAT
<p>ATEX HOPPER 0.38M³</p> <p>see separate instruction leaflet supplied with this accessory</p>		55 64339 00	MILD STEEL BODY PAINTED. STAINLESS STEEL 304 INLET AND DEFLECTOR PLATE.
<p>TI60DCFA 2.2KW/400/3/50</p> <p>TI60DCFA 4KW/400/3/50</p>		<p>55 64334 00</p> <p>55 64315 00</p>	MILD STEEL BODY AND BUCKET PAINTED WITH POLYESTER POWDER PAINT. STAINLESS STEEL 304 DEFLECTOR PLATE. ALUMINIUM INLET CASTING. FILTER SLEEVES IN ANTISTATIC POLYESTER NEEDLEFELT. SPRINGS IN ZINC PLATED MILD STEEL.

SPARES

We recommend that stocks be retained of the following:

55 64334 00 – TI60DCFA – 4KW / 400 / 3 / 50 - ATEX

QUANTITY	PART NUMBER	DESCRIPTION
1	01 87133 00	BELTS 8J 762
16	53 63154 01	FILTER SLEEVE 495mm ANTISTATIC
1	54 64314 00	INLET DEFLECTOR TUBE ASSEMBLY

55 64315 00 – TI60DCFA – 4KW / 400 / 3 / 50 - ATEX

QUANTITY	PART NUMBER	DESCRIPTION
1	01 87135 00	BELTS 8J 965
16	53 63154 01	FILTER SLEEVE 495mm ANTISTATIC
1	54 64314 00	INLET DEFLECTOR TUBE ASSEMBLY

PREPARATION FOR USE

RETURNING THE MACHINE TO BVC:

Please empty and thoroughly clean the machine so that it is safe to work on without personal protection equipment prior to return.

WET COLLECTION

SWARF BASKET ASSEMBLY – 54 63401 00

When fitting the basket and stand ensure the two locating pins are positioned so that the stub pipe penetrates the swarf basket.

Do not fill the swarf basket so full that it overflows or is it too heavy to lift.

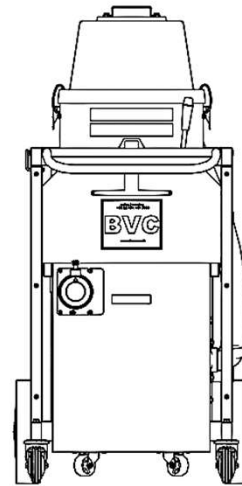
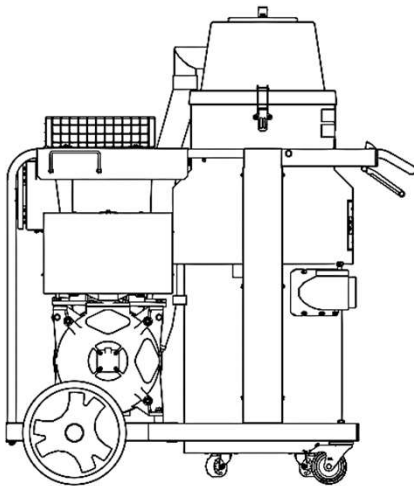

FLOAT VALVE ASSEMBLY – 54 63399 00

The float valve automatically closes when liquid reaches a predetermined level in the tank.

This is indicated by a change in sound of the vacuum cleaner and cessation of pick-up.

Do not fill the swarf basket so full that it overflows or is it too heavy to lift.

Check the float valve is clean and free to operate to use for wet pick-up.

MAINTENANCE

RECOMMENDED MAINTENANCE SCHEDULE

ITEM	FREQUENCY OF INSPECTION BASED ON 4 HOURS USE PER DAY	FREQUENCY OF REPLACEMTN BASED ON 4 HOURS USE PER DAY
Electrical supply cable	1 Month	When required
Static discharge route	1 Month	N/A
Drive Set (Belt and Pulleys)	3 Months	36 Months
Bearings Drive End	12 Months	36 Months
Bearings Non-drive End	12 Months	36 Months
Motor	As Per Motor Manufactures Instructions	As Per Motor Manufactures Instructions
Internal Impact Plate	Prior to Every Use When Collecting Ferrous Material Or 1 Month when collecting Non-Ferrous Metal	As Required
Clear Flow Filters	6 Months	24 Months
HEPA Filters	6 Months	24 Months
External Cleaning	Daily	N/A



DO NOT Carry out maintenance in a potentially explosive atmosphere.



ELECTRICAL SUPPLY Always disconnect the machine from electrical supply prior to carrying our maintenance.



EMPTY THE BIN Clean the filters prior to carrying out any maintenance.



ELECTRICAL CABLE Inspect the electrical supply cable for splits, cracks and damage and the integrity of the fittings at each end of the cable.



STATIC DISCHARGE ROUTE Check the static discharge route continuity between the pick-up nozzle and the electrical earth of the fixed electrical supply. This should be <math><800\text{M}\Omega</math>

BELT MAINTENANCE



WARNING – OVER TIGHTENING THE BELTS CAN GIVE RISE TO PREMATURE BEARING/BELT FAILURE AND EXCESSIVE TEMPERATURES.

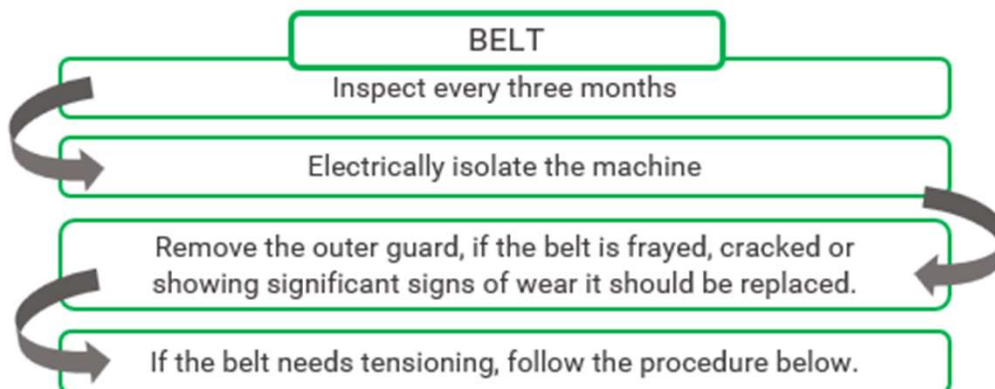

ENSURE

That the pulleys are clean and free from any dust build up. Ensure that the driving and driven shafts are parallel and that the pulleys are aligned by using a straight edge and adjusting the motor position accordingly. Always ensure that the motor is secured in position when adjustments are completed. If belt will not run true, the pulley shafts are either twisted in relation to one another or not parallel to one another.

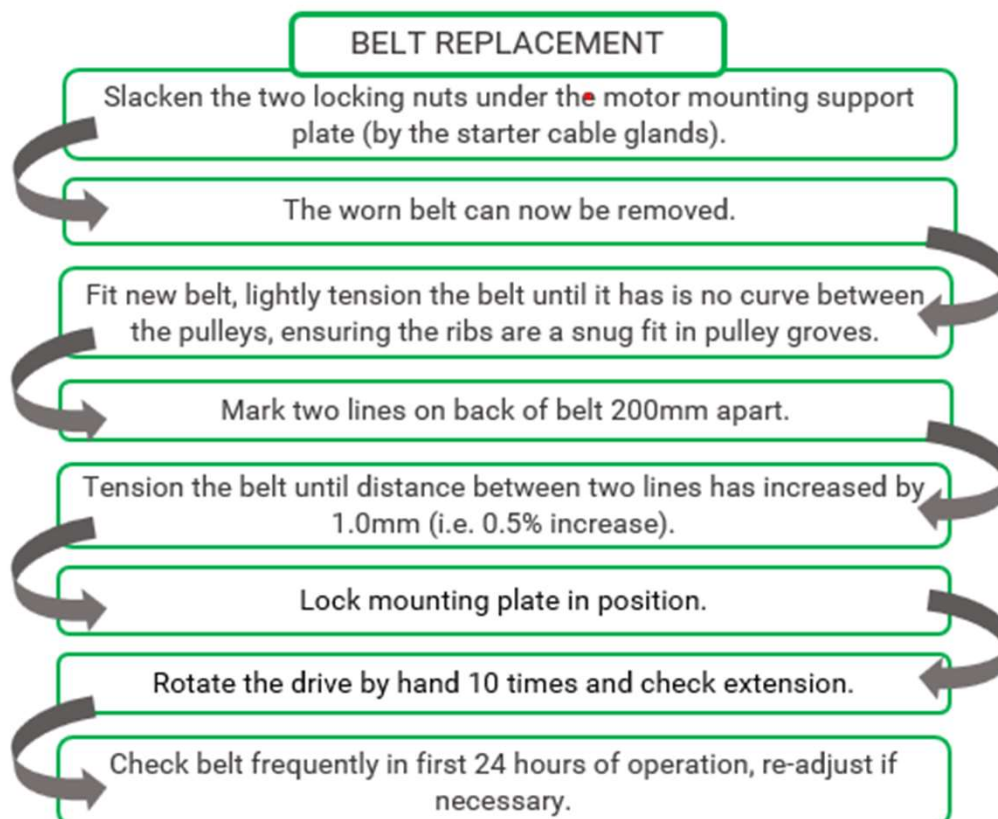

FILTER MAINTENANCE

CLEAR FLOW FILTERS - INSPECTION

Release the 2 toggle clips and remove the filter cover

Inspect the top of the spigot plate, which holds the clear flow filter sleeves

If the top surface of the spigot plate is clean or is covered in a thin film of very fine dust the filter is working correctly.

If the top surface of the spigot plate or the inside of the cover is covered with significant amounts of dust it indicates that a clearflow filter sleeve(s) is allowing dust through and needs changing.

CLEAR FLOW FILTER - CLEANING

Frequently clean the filter sleeves by using the filter manual shaker. This should be carried out with the machine powered off and the collection bucket fitted.

Ensure that the collection bucket is emptied regularly and is not allowed to become completely full. The collection bucket and contents may be very heavy and should be lifted carefully.



HEPA FILTERS

A good rule is to replace the HEPA filter every six months. This frequency is application dependant and can be adjusted to suit the usage.

Disconnect the flexible hose at the elbow on the filter cover at the top of the machine.

Inspect the inside of the flexible hose, the inside of the hose should be dust free, the presence of dust indicates the HEPA filter is allowing dust through and needs changing.

After filter replacements, or at 6 monthly intervals a filter efficiency check of the machine should be carried out to the requirements of BS 5415.

GENERAL CARE

BEARINGS

The exhauster has sealed bearings which require no maintenance. These bearings must be replaced after 40,000 hours use.

The drive end bearing should be inspected every six months for excessive play. .

Remove the belt and check for radial play on the drive shaft.

If the radial play is greater than 0.25mm then the drive end bearing needs changing.

As the exhauster will be stripped down the non drive end bearing should also be changed.

EXTERNAL CLEANING

Clean the machine on a daily basis or when accumulated dust layers are 5mm.

INTERCEPTOR COLLECTION DRUM

When using a separate interceptor drum, emptying and moving the drum must be carried out with the appropriate lifting equipment operated by a competent person.

INTERNAL IMPACT PLATE

Lift the knob on the hose connection bin.

Remove the inlet assembly.

Examine the impact plate to ensure there is no imbedded rust on the impact surface. If impacted rust cannot be removed, then the impact plate must be replaced.

Replace the inlet assembly and collection bin.



UKCA/EC DECLARATION OF CONFORMITY

(INDUSTRIAL VACUUM CLEANERS)

Manufacturer: - Quirepace Ltd, Pennant Park, Fareham, Hants, PO16 8XU

Authorised Representative: - Headlands Consulting Limited, Carrow Castle, Geevagh, Boyle, Co Roscommon, F52 FC89, Ireland

We QUIREPACE LTD DECLARE UNDER OUR SOLE RESPONSIBILITY THAT THE PRODUCT (S) DESCRIBED BELOW: -

TI80DLCFA 7.5kW 400V 3PH ATEX D22	55 64333 00	Serial No:	AF
TI80DLCFA 11kW 400V 3PH ATEX D22	55 64316 02	Serial No:	AG
TI80DLCFA 15kW 400V 3PH ATEX D22	55 64316 01	Serial No:	AH
TI60DCFA 2.2kW 400V 3PH ATEX D22	55 64334 00	Serial No:	BC
TI60DCFA 4kW 400V 3PH ATEX D22	55 64315 00	Serial No:	BD
TI60DCFA 4kW 400V 3PH ATEX G2 D22	55 65735 00	Serial No:	BD

UKCA Regulations:

Equipment and Protective Systems Intended for Use in Potentially Explosive Atmospheres Regulations 2016

Supply of Machinery (Safety) Regulations 2008

Electromagnetic Compatibility Regulations 2016

To which this declaration relates fulfil(s) the requirements of the following legislations and is/are in conformity with the listed standards:

BS EN 60335-1:2012+A15:2021	Household and similar electrical appliances. Safety - General requirements.
BS EN 60335 - 2 - 69: 2012	Particular requirements, for wet and dry vacuum cleaners, including, power brush for industrial and commercial use.
BS EN 61000 - 6 - 4: 2019	Electromagnetic compatibility (EMC) - Generic standards. Emission standard for industrial environments
BS EN ISO 80079-36:2016	Explosive atmospheres - Non-electrical equipment for explosive atmospheres. Basic method and requirements
BS EN ISO 80079-37:2016	Explosive atmospheres - Non-electrical equipment for explosive atmospheres. Non-electrical type of protection constructional safety "c", control of ignition sources "b".
BS EN IEC 60079-0:2018	Explosive atmospheres. Equipment. General requirements

Certification codes:

Dust Environments

UK CA CE  II 3 D Ex tc IIIC T135°C Dc

Gas Environments

UK CA CE  II 3 G Ex ec IIB T4 Gc

The product fulfils the following relevant provisions:

Machinery Directive	2006/42/EU
ATEX Directive	2014/34/EU
Electromagnetic Compatibility Directive	2014/30/EU

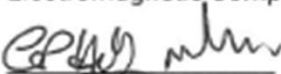
 G Hall / M Brown

Senior Engineers

 R Pescott

Managing Director

DATE 15/04/2024